



Compressed Air & Gas Treatment and Gas Generation

Product Line Card



ENGINEERING YOUR SUCCESS.

Focused On Engineering Excellence

Parker's Industrial Gas Filtration and Generation Division redefines compressed air treatment and gas generation with premier solutions. Our vast product line includes compressed air filters, condensate management products, refrigerated and desiccant air dryers, breathing air purifiers, nitrogen gas generators, process water chillers and CO2 quality incident protection systems.

Our products are engineered for utilization in many diverse markets, industries and applications where compressed air and gas purity, product quality and technological excellence are paramount.





Industrial Nitrogen Gas Generators

Approximately 90% of the global consumption of nitrogen is supplied traditionally in the form of gas cylinders, or as a liquid in mini tanks or large bulk liquid storage vessels. With traditional methods of gas supply, users are responsible for hidden extra costs such as cylinder rental, delivery and administration charges on top of the headline gas price.

Additionally, traditional gas supply methods result in waste. Liquid boil-off from dewars vents expensive gas into the atmosphere, and approximately 10% of the gas in every cylinder is returned to the supplier unused. When the true costs are accounted for, on-site gas generation is the most economical source of nitrogen. Subsequently, nitrogen gas generators give users control over their gas pressure, purity and flowrate and minimize production downtime due to the permanent availability of an on-demand nitrogen supply.

Parker's NITROSource Series PSA Nitrogen Gas Generators produce nitrogen at purities up to 99.9995%, and dewpoints as low as -58°F . Supported by substantially lower servicing costs, reduced downtime and a longer working life than comparable nitrogen generators, the NITROSource Series offers the most economical nitrogen supply available; significantly more affordable and safer than traditional delivery methods of supply.

Series	Purity Range	Flow Range*
NITROSource Compact	Up to 99.999%	Up to 1338 scfh
NITROSource	Up to 99.9995%	Up to 5474 scfh

*Additional flow rates can be achieved through multi-bank installations. Please contact Parker Applications team for more information.

Twin Tower Desiccant Air Dryers

For critical applications that require very dry air or facilities that have compressed air pipework in subfreezing environments, a desiccant (aka adsorption) dryer is required. Parker is a leading manufacturer of various types of regenerative desiccant dryers – each designed to supply high quality compressed air in accordance with ISO8573-1, the international standard for compressed air quality.

Parker's TW Series Heatless Desiccant Compressed Air Dryers are the simplest adsorption dryer technology and have long been the dryer of choice for many industries and applications. These dryers use a process called pressure swing adsorption to remove water vapor from compressed air. For regeneration, heatless dryers utilize 15% of the dried process air to purge the off-line, saturated desiccant bed. TW dryers are simple, reliable, cost-effective, and best-suited for small to medium flow systems.

Parker's TWP Series Externally Heated Desiccant Compressed Air Dryers integrate an external heater to aid in the regeneration process. With the addition of heat and extending the dryer's cycle time, these dryers reduce the amount of dry purge air down to 8%. — saving energy and money.

Parker's TWB Series Blower Purge Desiccant Compressed Air Dryers integrate both an external blower and heater to significantly reduce the purge rate down to 0-2%, making them one of the most energy efficient dryers on the market.

Fitted with a state-of-the-art Allen Bradley® PLC and a plethora of standard features that alternative dryers offer as optional, Parker twin tower desiccant dryers offer the highest value, while maintaining industry leading performance, quality and reliability.

Dryer Series	Technology	Flow Rates*
TW	Heatless	55 – 3,000 scfm
TWP	Externally Heated	200 – 7,500 scfm
TWB	Blower Purge	200 – 7,500 scfm

*Flowrates are at the following climatic conditions - Ambient Temperature: 100°F (38°C), Inlet Temperature: 100°F (38°C), Inlet Pressure: 100 psi g (7 bar g). Consult Parker for performance under specific conditions.



Modular Desiccant Air Dryers

With the proven benefit of advanced aluminum forming technology, Parker has developed a modular twin tower desiccant dryer that is typically 60% of the size and weight of conventional twin tower designs and offer one of the simplest and most cost-effective compressed air drying solutions.

Parker's CDAS HL Series Clean Dry Air Systems and OFAS HL Series Oil Free Air Systems combine the sophisticated OIL-X filtration technology, an optimized drying system and energy savings technology as standard to provide consistent high performance over an extended period of time.

Fitted with a third adsorbent column for oil vapor removal, Parker's OFAS HL Oil Free Air Systems have been third party validated by Lloyds register to provide ISO 8573-1 Class 0, with respect to total oil from both oil lubricated and oil free compressors, ensuring the highest quality air at the point of use for critical applications.

Parker's MX Series modular construction allows for greater flexibility. It can be multi-banked to provide extra compressed air-drying capacity should demand increase. This distinctive feature allows 100% redundancy at a fraction of the cost of a traditional twin tower dryer and allows individual dryers to be easily isolated for routine service work, while maintaining the plants clean, dry air supply.

With Parker's modular dryers, minimum total cost of ownership and the best cost-benefit ratio of any high-quality air treatment solution are guaranteed through reduced service times, more simplicity in the replacement of parts, extended maintenance periods and longer operational life.



Dryer Series	Technology	Flow Rates*
K-MT	Heatless	5 - 20 scfm
CDAS	Heatless	32 - 177 scfm
OFAS	Heatless	32 - 177 scfm
MX	Heatless	240 - 3600+ scfm

*Flowrates are at the following climatic conditions - Ambient Temperature: 100°F (38°C), Inlet Temperature: 100°F (38°C), Inlet Pressure: 100 psi g (7 bar g). Consult Parker for performance under specific conditions.

Portable Desiccant Air Dryers

To achieve the stringent air quality levels required for today's modern production facilities, a careful approach to system design, commissioning and operation must be employed. Compressed air treatment using just one purification technology is not enough to achieve high purity levels defined by ISO8573-1. Multiple stages of purification should be utilized to ensure the most effective solution for high quality compressed air.

Parker's PPD Series Portable Desiccant Air Dryers are designed with 2 stage coalescing pre-filters to remove contaminants before the compressed air enters the desiccant bed and post-filters are mounted at the outlet of the dryer to remove any dust from going downstream. An optional integrated aftercooler and water separator can be added if the

compressed air needs to be cooled before entering the dryer. Packaged on a portable, heavy-duty skid and coupled with an Allen Bradley PLC®, these highly engineered systems offer top-of-the-line durability and ensure high quality compressed air in accordance with ISO8573-1.

Whether it's an unexpected emergency or planned maintenance, rely on Parker's PPD series to ensure protection of your equipment and product from contamination caused by untreated compressed air.

Dryer Series	Technology	Max. Pressure	Flow Rates*
PPD	Heatless	150 PSI g	500-3000 scfm
PPD-350	Heatless	350 PSI g	1800-2800 scfm

*Flowrates are at the following climatic conditions - Ambient Temperature: 100°F (38°C), Inlet Temperature: 100°F (38°C), Inlet Pressure: 100 psi g (7 bar g). Consult Parker for performance under specific conditions.



*Achieving pressure dewpoints lower than -40°F require dryer operation in Short Cycle mode and an increased purge rate. Consult factory or user manual for more information.



Rental Oil Vapor Removal System (ROVR)

Parker's ROVR Oil Vapor Removal System is designed to deliver compressed air in accordance with ISO8573-1 Class 0 for Total Oil when installed downstream of a desiccant air dryer that is installed with proper coalescing and particulate filtration.

The ROVR is a cartridge-based filtration system that is designed, tested and third-party performance certified to reduce oil vapor down to ≤ 0.003 mg/m³. This adsorption filtration system pairs easily with any of Parker's PPD Series dryers 1600 scfm or smaller to deliver 'Technically Oil Free Compressed Air' from either oil-free or oil-lubricated compressors.

Similar to Parker's Portable Desiccant Compressed Air Dryers, the ROVR is constructed with a rugged, heavy-duty "sled-style" skid. This allows for easy transportation with designed lifting lugs and forklift holes.

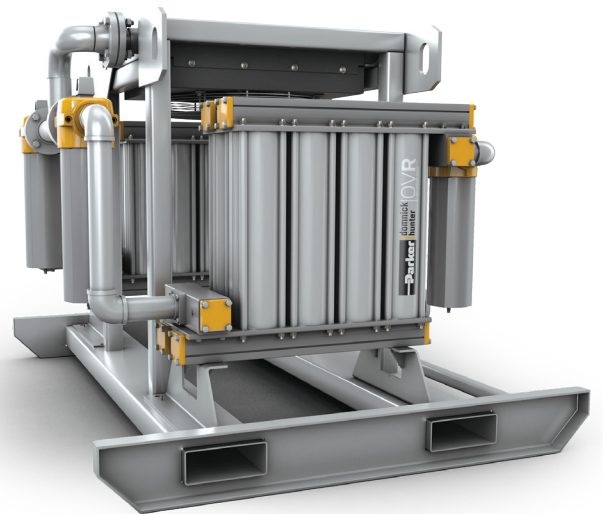

Refrigerated Air Dryers

Parker manufactures non-cycling and cycling refrigerated air dryers that provide solutions for a broad range of applications, ensuring peak performance and efficiency of downstream equipment, processes, and product. Parker's refrigerated compressed air dryers are designed with low global warming potential (GWP) refrigerants that help protect the environment, while ensuring the dryer is energy-efficient and cost-effective for the customer.

For those looking to improve their compressed air quality at a lower up front cost, Parker offers the **SPS Series Non-Cycling Refrigerated Compressed Air Dryers**. Non-cycling dryers operate constantly, regardless of the compressed air load coming into the dryer. These economical refrigerated air dryers offer consistently low dewpoints at the lowest capital costs.

PSE Series Cycling Refrigerated Compressed Air Dryers are equipped with Parker's patented SmartSave technology, which monitors key parameters of the cooling process and cycle the refrigerant compressor off during times of low load without the added componentry and complexity of traditional cycling dryer technologies. This results in a low energy consumption dryer at a lower capital cost.

Designed to work with R-513A refrigerant, SPS and PSE dryers have a remarkably low GWP that is up to 85% lower than alternative refrigerants widely used in other refrigeration dryers. Both series comply with the requirements of the United States Environmental Protection Agency and European F-Gas Regulation – making them the best choice to protect the environment and your investment against regulations aimed at phasing out high GWP refrigerants.

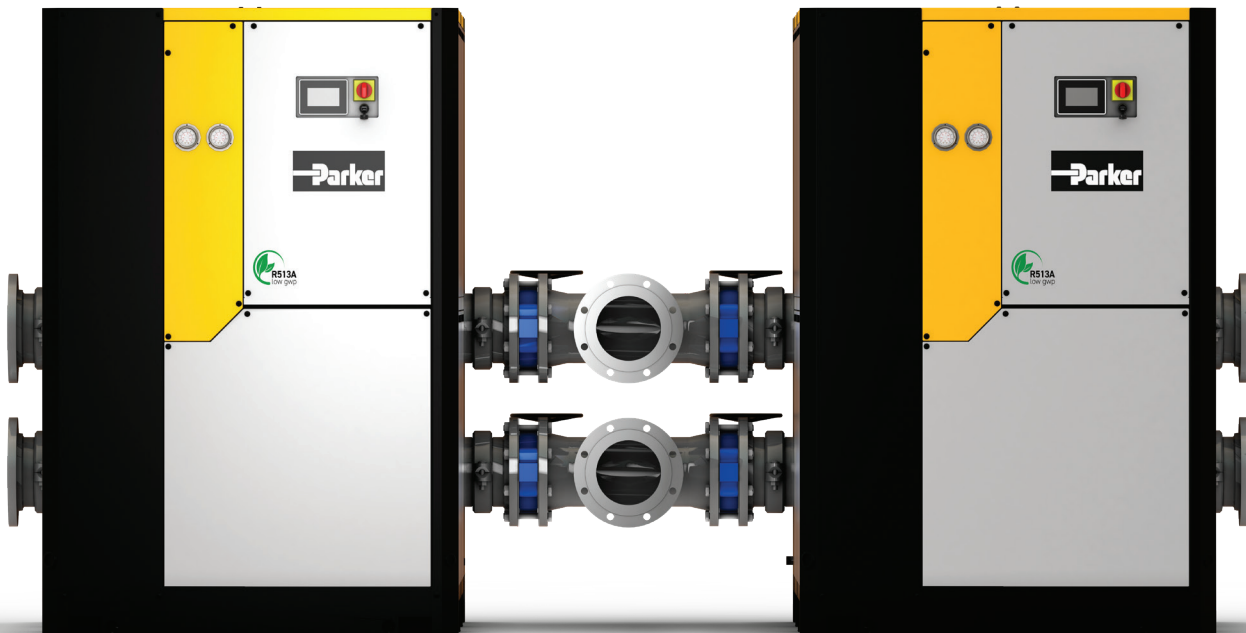

Dryer Series	Technology	Flow Rates*
SPS	Non-Cycling	10 – 250 scfm
PSE	Cycling	325 – 6,000 scfm
Dual Installation PSE	Cycling	7,600 – 12,000 scfm

*Flowrates are at the following climatic conditions - Ambient Temperature: 100°F (38°C), Inlet Temperature: 100°F (38°C), Inlet Pressure: 100 psi g (7 bar g). Consult Parker for performance under specific conditions.



Compressed Air Filters

The Parker OIL-X range of diecast compressed air filters has been designed from the outset to meet the air quality requirements of all editions of ISO8573-1, when validated in accordance with the stringent requirements of ISO12500-1.

An efficient and sensible manufacturing process is a major factor in maintaining the profitability and growth of your business. All Parker OIL-X products are designed to not only minimize the use of compressed air and electrical energy in their operation, but also to significantly reduce the operational costs of the compressor by minimizing pressure loss. OIL-X filters incorporate a number of unique and patented design features to minimize differential pressure and provide a filter and element combination where the differential pressure starts low and stays low to maximize energy savings and provide the lowest lifetime costs without compromising air quality.

Parker OIL-X also offers a range of fabricated carbon steel compressed air filters that combine an innovative filter housing and filter element design to achieve optimum flow characteristics with minimum pressure drop, resulting in considerable cost savings throughout the entire operating lifetime of the filter element.



The filter housing has been designed for ease of maintenance. A low placed service flange, supported by a pivoting hinge joint, enables element replacement to be undertaken by a single individual. A dished housing bottom provides ample space to drain away liquids efficiently, and the patented filter element design provides a secure seal to avoid any possibility of contamination bypassing the element.

All fabricated filters are “U” stamped and conform to ASME Section VIII standard code for pressure vessels. With large flow capacities and optional materials of construction, most compressed air filtration requirements can be met.

Range	Grades	Port Sizes	Flow Ranges
OIL-X Diecast	Water Separator, Coalescer, Particulate, Adsorption (carbon)	1/4" to 3" NPT	21 – 1,314 scfm
OIL-X Fabricated		3" to 12" FLG	911 – 16,528 scfm

Stated flow rates are for operation at 100 psi g (7 bar g) with reference to 68°F (20°C), 14.5 psi g (1 bar g), 0% relative water vapor pressure.

PCO2 Series Carbon Dioxide Quality Incident Protection Systems

PCO2 Carbon Dioxide Quality Incident Protection Systems from Parker offer a comprehensive solution to preserve and guarantee the quality of gaseous carbon dioxide used in sparkling beverage bottling.

Operating as a quality incident protection system, the PCO2 series was designed in accordance to ISBT beverage specifications for CO2 bottling. Using multi-layer adsorbent technology, the design ensures that unwanted contaminants & impurities are removed, ensuring the CO2 sent downstream is in compliance with industry and company guidelines. The PCO2 series provides peace of mind for the producer, reduces the chance of a product recall and protects the company's reputation.

The PCO2 system is approved and recommended by major global brand leaders and is the preferred choice when it comes to guaranteeing the quality of gaseous carbon dioxide used in bottling applications. The Parker PCO2 system is installed in over 150 countries worldwide and the number of installations is increasing as the sparkling beverage industry continues to grow year over year.

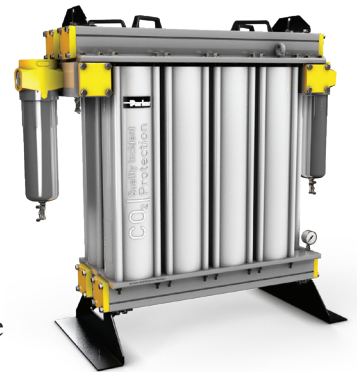

Series	Technology	Flow Rates*
PCO2	ISBT beverage grade CO2	400 - 9,600 Lb/h @ 350 psig

*All systems are rated at a maximum operating pressure of 24.1 Bar g / 350 psi g, with exception to PCO2-400 rated at 20.7 Bar g / 300 psi g

Industrial Process Water Chillers

For over 40 years, Parker has been developing and manufacturing market leading products to meet the cooling requirements across a wide range of industries. The Parker chiller range offers the ideal solution for industrial cooling processes that require: energy efficiency, reliability, continuous operation and reduced maintenance costs.

Parker's precision water cooling technology is split into two main product ranges: Hyperchill and Hyperchill Plus.

The Hyperchill and Hyperchill Plus range of chillers can deliver cooling capacity from 4,668 to 648,981 BTU/h, and are suitable for internal and external installations. Water and air-cooled condenser versions can be supplied with a range of power supplies and UL stamp

for North America. Parker offers a variety of configurations that can be selected based on the application and environment that the chiller will be installed in, providing flexibility and versatility to meet the cooling needs in all industrial applications.

Each individual Hyperchill and Hyperchill Plus unit is extensively tested to guarantee efficient operation and reliability under all working conditions.



Parker Filtration Group

Aerospace Filtration Division

Greensboro, North Carolina
336 668 4444

Bioscience & Water Filtration Division

Bioscience Filtration
Oxnard, California
877 784 2234

Water Purification
Carson, California
310 608 5600

Engine Mobile Aftermarket Division

Kearney, Nebraska
308 234 1951

Engine Mobile Original Equipment Division

Modesto, California
209 521 7860

HVAC Filtration Division

Jeffersonville, Indiana
866 247 4827

Hydraulic & Fuel Filtration Division

Metamora, Ohio
419 644 4311

Industrial Gas Filtration & Generation Division

Lancaster, NY
800 343 4048

Industrial Process Filtration Division

Mineral Wells, Texas
940 325 2575

Bioscience Engineering Filtration Division EMEA

Birtley, United Kingdom
+44 (0) 191 410 5121

Engine Mobile Filtration Division EMEA

Dewsbury, United Kingdom
+44 (0) 1924 487 037

Gas Separation & Filtration Division EMEA

Team Valley, United Kingdom
+44 (0) 191 402 9000

Gas Turbine Filtration Division

Alton, United Kingdom
+44 (0) 1420 541188

Hydraulic & Industrial Filtration Division EMEA

Arnhem, Netherlands
+31 (0) 26 376 0376

Australia Filtration Division

Castle Hill, Australia
+61 2 9634 7777

China Filtration Division

Shanghai, China
+86 21 2067 2067

India Filtration Division

Chennai, India
+91 22 4391 0700

Korea Filtration Division

Hwaseon City, Korea
+82 31 359 0852

Latin America Filtration Division

Sao Paulo, Brazil
+55 12 4009 3500



© 2023 Parker Hannifin Corporation. Product names are trademarks or registered trademarks of their respective companies.

BRO_PKR_CGFC Linecard_042023



Parker Hannifin Corporation
**Industrial Gas Filtration
and Generation Division**
4087 Walden Ave.

Lancaster, NY 14086
phone 800 343 4048
www.parker.com/igfg